

**PV**  
(ceiling 600x600)

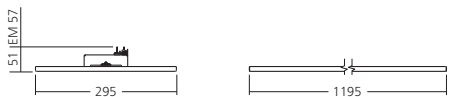

**PR**  
(ceiling 625x625)

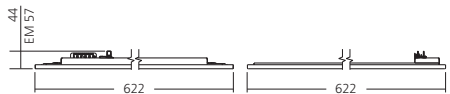

EN The fitting cannot be covered with insulating material.  
 D Nicht zur Abdeckung mit Wärmedämmmaterial geeignete Leuchte.  
 F L'article ne peut être recouvert de matériaux isolants.  
 E El aparato no podrá cubrir con material aislante.  
 RUS Осветительный прибор не может быть покрыта изоляционным материалом.  
 I Il portalampane non può essere ricoperto con materiale isolante.  
 PL Oprawa nie może być pokryta materiałem izolacyjnym.  
 SK Svetidlo nesmie byť pokryté izolačným materiálom.  
 CZ Světlo nesmí být kryto izolačním materiálem.

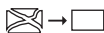

EN Replace any cracked protective shield.  
 D Defekte Sicherheitsgläser austauschen.  
 F Remplacer tout écran de protection fissuré.  
 E Reemplace cualquier agrietado escudo protector.  
 RUS Замените любые трещины защитного щита.  
 I Sostituire gli schermi danneggiati.  
 PL Wymienić uszkodzone klosze.  
 SK Prasknutý kryt vymeniť.  
 CZ Prasknutý kryt vyměnit.



EN The light source contained in this luminaire shall only be replaced by the manufacturer or his service agent or a similar qualified person.  
 D Die Lichtquelle in dieser Leuchte darf nur der Hersteller, Vertragsservicetechniker oder eine qualifizierte Person austauschen.  
 F La source lumineuse dans cette luminaire peut être changée seulement par le producteur, le contractual service technician ou la personne avec la similaire qualification.  
 E La fuente de luz de esta luminaria no se puede cambiar, cuando la vida de la fuente de luz se acaba se debe de reemplazar toda la luminaria.  
 RUS Источник света в данном светильнике может быть заменён только производителем, сервисным техником или другим квалифицированным специалистом.  
 I La sorgente di luce contenuta in questo apparecchio è sostituito solo dal costruttore o suo agente servizio o una persona qualificata simile.  
 PL Źródło światła umieszczone w tej oprawie powinno być wymieniane tylko przez producenta, autoryzowanego serwisanta, lub osobę posiadającą odpowiednie kwalifikacje.  
 SK Svetelný zdroj v tomto svetidle smie vymeniť len výrobca, zmluvný servisný technik, alebo podobne kvalifikovaná osoba.  
 CZ Světelný zdroj v tomto světidle smí vyměnit pouze výrobce, smluvní servisní technik, nebo podobně kvalifikovaná osoba.

| TEST<br>(Monthly) | YEAR 1 |        | YEAR 2 |        | YEAR 3 |        | YEAR 4 |        | YEAR 5 |        |
|-------------------|--------|--------|--------|--------|--------|--------|--------|--------|--------|--------|
|                   | Date   | Signed | Date   | Signed | Date   | Signed | Date   | Signed | Date   | Signed |
| Functional        |        |        |        |        |        |        |        |        |        |        |
| Functional        |        |        |        |        |        |        |        |        |        |        |
| Functional        |        |        |        |        |        |        |        |        |        |        |
| Functional        |        |        |        |        |        |        |        |        |        |        |
| Functional        |        |        |        |        |        |        |        |        |        |        |
| Functional        |        |        |        |        |        |        |        |        |        |        |
| Functional        |        |        |        |        |        |        |        |        |        |        |
| Functional        |        |        |        |        |        |        |        |        |        |        |
| Functional        |        |        |        |        |        |        |        |        |        |        |
| Functional        |        |        |        |        |        |        |        |        |        |        |
| Functional        |        |        |        |        |        |        |        |        |        |        |
| Three Hour        |        |        |        |        |        |        |        |        |        |        |

Luminaire Ref/Location

In Case of difficulty,  
contact the Installation  
Engineers

tel:

EN INSTALLATION INSTRUCTIONS  
 D MONTAGEANLEITUNG  
 F MANUEL D'INSTALLATION  
 E INSTRUCCIÓN DE MONTAJE  
 RUS ИНСТРУКЦИЯ ПО МОНТАЖУ  
 I ISTRUZIONI DI MONTAGGIO  
 PL INSTRUKCJA MONTAŻU  
 SK NÁVOD NA MONTÁŽ  
 CZ NÁVOD K MONTÁŽI

X12340M-01



**oms**®



OMS, a.s., Dojč 419, 906 02 Dojč, Slovakia

**FREYN II**

**EN** Turn off the power prior to light fixture installation! The light fixture may be installed only by a qualified person! The light fixture must be wired according to respective electrical standards. The manufacturer shall not be liable for any modifications of the product of incorrect installation of the product. **D** Schalten Sie den Strom vor der Installation der Leuchte aus! Die Leuchte darf nur von einer Person mit entsprechender Qualifizierung angeschlossen werden. Die Leuchte muss gemäß einschlägiger elektronischer Normen angeschlossen werden. Der Hersteller übernimmt keine Haftung, soweit das Produkt geändert, modifiziert oder unsachgemäß installiert wurde. **F** Avant l'installation du luminaire coupez le courant. Le luminaire doit être branché uniquement par une personne qualifiée selon les normes d'installations en vigueur. Le fabricant ne porte aucune responsabilité dans le cas d'une modification du produit ou d'une mauvaise installation. **E** Antes de proceder al montaje, desconecte la corriente eléctrica! La luminaria ha de ser conectada solamente por la persona que posee la calificación adecuada! La luminaria ha de ser conectada solamente en conformidad con las normas electrotécnicas correspondientes. En caso en que de ser el producto fue modificado o instalado incorrectamente, el fabricante no asume responsabilidad alguna. **RUS** Перед началом монтажа отключите электрическое питание! Подключение светильника может выполнять исключительно специалист, обладающий соответствующей электротехнической квалификацией! Подключение светильника должно производиться соответствии с действующими электротехническими нормами и правилами. Производитель не несет никакой ответственности за последствия, вызванные вмешательством в конструкцию светильника или неправильной установкой. **I** Prima di installare l'apparecchio di illuminazione spegnere la corrente! L'apparecchio può essere allacciato unicamente da persona appositamente qualificata! L'apparecchio va allacciato in conformità delle rispettive norme vigenti nel campo dell'elettrotecnica. Il costruttore è sollevato da qualsiasi responsabilità in caso di manomissione o errata installazione del prodotto. **PL** Przed instalacją lampy należy wyłączyć dopływ prądu! Oświetlenie może podłączyć wyłącznie osoba posiadająca odpowiednie kwalifikacje! Oświetlenie należy podłączyć zgodnie ze stosownymi normami elektrotechnicznymi. Producent nie ponosi odpowiedzialności w przypadku ingerencji w wyrób lub nieprawidłowej instalacji. **SK** Pred inštaláciou svietidla vypnite prúd! Svetidlo môže byť zapojené iba osobou s príslušnou kvalifikáciou! Svetidlo musí byť zapojené podľa príslušných elektrotechnických noriem. Výrobca neberie žiadnu zodpovednosť ak bol výrobok upravovaný prípadne nesprávne nainštalovaný. **CZ** Před instalací svítidla vypněte proud! Svítidlo může být připojováno pouze osobou s příslušnou kvalifikací! Svítidlo musí být připojeno podle příslušných elektrotechnických norem. Výrobce nebere žádnou zodpovědnost, pokud byl výrobek upravený, případně nesprávně nainstalován.

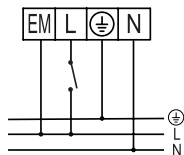
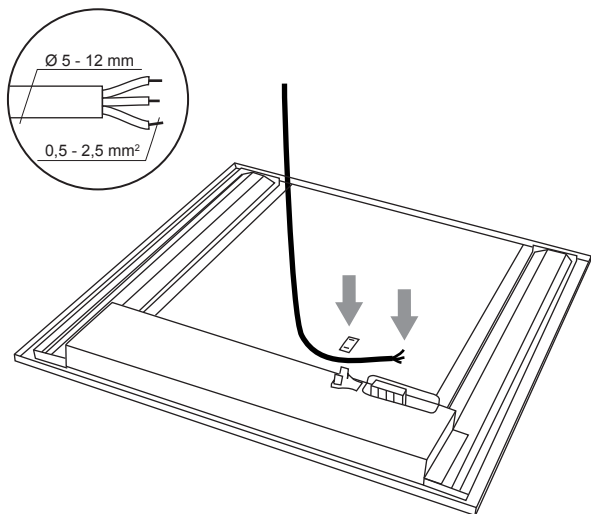

Ambient Temperature  
0°C to 35°C

Lumen output  
410/430 lm (3000K/4000K)

#### Important

These instructions contain important safety information. The manufacturer does not accept any responsibility for injuries, damages or losses, which may be incurred as a result of incorrect installation, operation, maintenance or disposal. Make sure that the required voltage and frequency are in accordance with stated parameters. When connected to the electrical grid, ensure correct polarity.

The installation must be performed by a person qualified under national and local regulations.

The results of testing must be recorded. If they are not recorded, it is a reason not to accept a claim.

The battery needs to be replaced after 4 years or in case that the light fixture does not reach the nominal lifespan.

#### Functional test

Functional tests are carried out for 5 seconds on a weekly basis under the control of the Micro controller. Initiation and timing of these tests is set during the commissioning of the luminaire.

Duration test: A full duration test is carried out yearly to check the capacity of the batteries.

#### Commissioning

After installation of the luminaire and initial connection of the mains supply and battery supply to the EM powerLED ST the unit will commence charging the batteries for 20 hours (initial charge). Afterwards the module will conduct a commissioning test for the full duration. The 20 hours recharge occurs also if a new battery is connected or the module exits the rest mode condition. The following automatic commissioning duration test is only performed when a battery is replaced and fully charged (after 20 hours).

#### Batteries

The nickel-cadmium batteries used in this light fixture contain electrolyte that can be dangerous for the eyes and poisonous for open wounds. When manipulating with the batteries, it is necessary to avoid breaking the cover. If the electrolyte gets in contact with the skin, immediately rinse the affected area with water. The batteries must not be exposed to overcharging or discharging current. When manipulating with the batteries, take care that there is no short circuit with other devices, jewelry, etc. Do not burn batteries. The disposal of batteries must be in accordance with national and local regulations.

System status is indicated by a bi-colour LED.

| LED Indication                             | Status                 | Commentary   |
|--|------------------------|--|
| Permanent green                            | System OK              | AC mode  |
| Fast flashing green (0.1 s on – 0.1 s off) | Function test underway |  |
| Slow flashing green (1 s on – 1 s off)     | Duration test underway |  |
| Red LED on                                 | Load failure           | Open circuit / Short circuit / LED failure   |
| Slow flashing red (1 s on – 1 s off)       | Battery failure        | Battery failed the duration test or function / Battery is defect / Incorrect battery voltage |
| Fast flashing red (0.1 s on – 0.1 s off)   | Charging failure       | Incorrect charging current   |
| Double pulsing green                       | Rest mode              | Switching into blocking mode via controller  |
| Green and red off                          | DC mode                | Battery operation (Emergency mode)   |

